



June Tailor, Inc.

# Custom Valance Measuring Instructions

## Tips:

- Use only a steel tape measure. Cloth tape measure can stretch.
- Take measurements as directed as not all windows are square.
- Measure windows more than once to ensure accuracy.
- If ordering treatments for multiple windows, measure each window individually.

## Outside Mount:

Provide dimensions to the nearest whole inch.

A. Outside width of window.

\* Include molding in measurement.

B. Top of window to ceiling.

\* Measure from outer edge of molding. Ensures clearance for window treatment.

C. Side of window to obstruction (wall or other window).

\* Include molding. Ensures clearance for window treatment.

1. Width: Measure for the exact width that you wish to cover.

\* If no undertreatments are being used, 1" beyond both sides of molding is recommended.

\* If undertreatments are being used, 2" beyond both sides of undertreatment are recommended.

WIDTH \_\_\_\_\_

2. Return: Select return size from 3", 6" or 8".

\* If no undertreatments are being used, 3" return is recommended.

\* If undertreatments are being used, 6" or 8" returns are recommended.

RETURN \_\_\_\_\_

## Inside Mount:

Provide dimensions to the nearest 1/8".

A. Top opening.

\* Inside width of opening to the nearest 1/8".

B. Desired drop.

\* Treatments are available in a variety of drop options.

C. Opening at drop level.

\* Inside width of opening at the bottom of the treatment drop to the nearest 1/8".

1. Width: Use the narrower of widths A and C to determine the width of your finished treatment.

WIDTH \_\_\_\_\_

## All Treatments:

3. Drop: If options are available, select the drop (measurement from top to bottom) that's proportionate to your window.

DROP \_\_\_\_\_

4. Fabric:

\* A single fabric option is available on all window treatments.

\* Select styles available with a second contrast fabric.

FABRIC \_\_\_\_\_

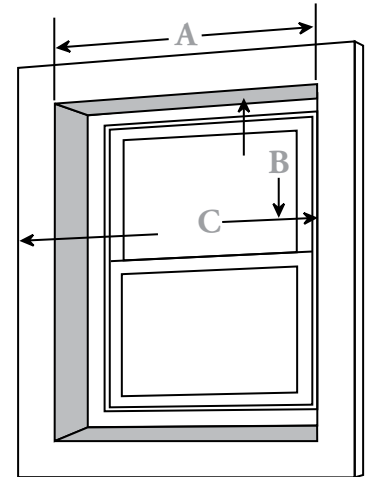
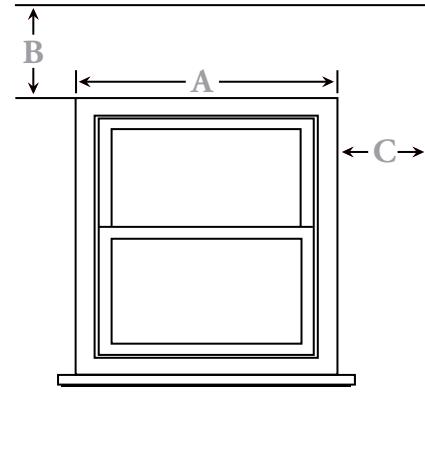

June Tailor, Inc.

2861 Highway 175, P.O. Box 208, Richfield, WI 53076 • Phone: 1-800-844-5400 • Fax: 1-262-644-5061